

## Q Automatic

Conveyorized Stretch  
Wrapping System



Unlimited Cycles  
No Exclusions

### Productivity

Providing creative solutions to help  
customers increase productivity.

#### Operator-Friendly Design

- No trip hazards or pinch points.
- Easy to navigate touch screen.
- Clear access to load film.
- Fully guarded film roll carriage.

#### Efficient Load Handling

- Wraps 45-60 loads per hour.
- Industrial duty conveyor, closed-space rollers, 4000 lbs. capacity.
- Options available to custom build to meet specific needs.
- Eliminate forklift jams.

Note: Shown without  
safety fencing.

Q Automatic



# Q Automatic

## Clean Design

- Motors, wires, belts enclosed.
- No trip, burn or pinch hazards.

## Transition Photocells / System Guarding

- Transition photocells mounted on either side of the turntable for easy access.
- If photocell beam is broken during the wrap cycle, the machine will immediately shut down.
- Complete system guarding and safety signage standard on all models.

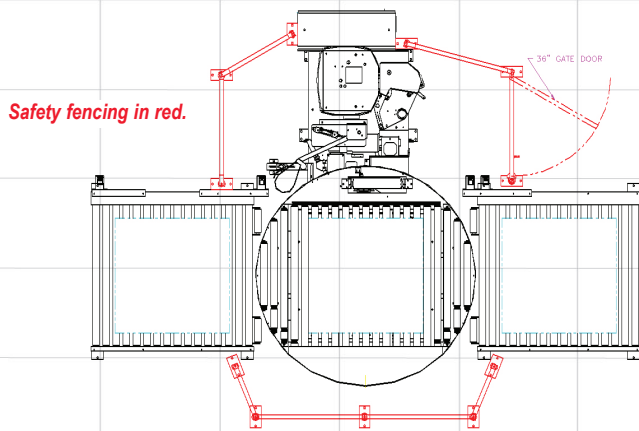

## Safe, Convenient Film Loading

- Safe, unobstructed access to roll carriage for film loading from the side.

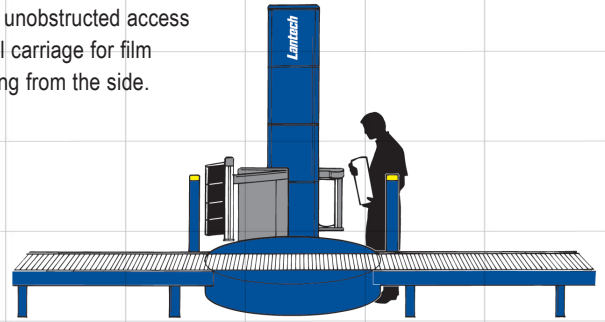

## "Touchless" Film Cutting System

- Cutter wire safely guarded and hot only when necessary.
- Length of time for heated impulse is adjustable for film thickness and ambient temperature.
- Cutter wire does not come into contact with film, eliminates film build-up on wire for a clean, consistent cut.

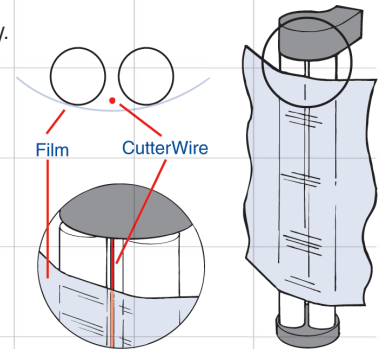

## Q Automatic Specifications

### PERFORMANCE CRITERIA

- Production Speed based on 60" load height, 2 film layers and 10 revolutions 45 loads per hour
- Maximum Load Size 48"W x 54"L x 92"H
- Minimum Load Size 36"W x 36"L x 24"H
- Maximum Load Weight 4000 lbs.

### LOAD HANDLING SYSTEM

- Turntable Drive 1 HP TEFC Motor
- Turntable Speed 1-12 RPM

### FILM DELIVERY SYSTEM

- Power Roller-Stretch® System 200% Standard 100-300% Available
- Wrapping Force Electronic Control
- Film Capacity 10" Roll Diameter, 20" Film Web Width
- Film Cut System Reach® Arm with impulsed hot wire film cutter

### MACHINE SHIPPING WEIGHT

- Shipping Weight (including skid - approximate) 7250 lbs. (includes 5' infeed and 5' exit conveyor)

### ELECTRICAL REQUIREMENTS

- Machine Voltage 460V
- System Logic PLC/Touchscreen
- Control Panel NEMA 12-enclosure with disconnect and safety lock-out

### PNEUMATIC DATA

- Air requirements 3-5 CFM @ 80 psi clean, dry air

### SERVICE SUPPORT

24 hours/7 days a week

Specifications subject to change without notice. Lantech systems and sub-systems are protected by U.S. and foreign patents. Additional U.S. and foreign patents pending. © Lantech.com 2007

**shorr** | packaging corp.  
shorr.com 888.885.0055

## Lan-Logix™

The Lan-Logix interface leads the industry to boost productivity by eliminating the need for costly software and hardware to make minor program changes. Included are multiple wrap patterns, precise wrap pattern control, password protection, and extensive efficiency data capture.

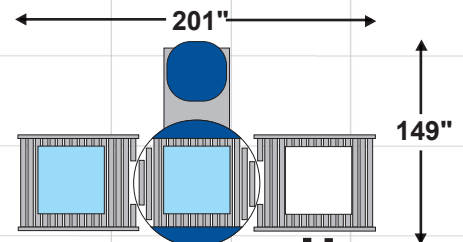

Note: Side loading may require additional conveyor.

